



Features

- Parallel outputs for feeding additional units
- 95° horizontal dispersion
- QuickMount bracket for fast, easy and secure installation
- High-power handling capability and rugged plywood enclosure optimized for digital soundtrack reproduction
- THX™ approved for professional cinema applications

Developed specifically for the unique requirements of professional motion picture playback, QSC extends its commitment to the cinema market with the introduction of the SR-110B Cinema Surround Loudspeaker. As a member of QSC's DCS Digital Cinema Speaker Series, the SR-110B offers high-power handling, excellent sensitivity, and extended bass response in a very compact enclosure.

The SR-110B Cinema Surround Loudspeaker features a high-power, long-throw 10" low-frequency transducer coupled with a 1" titanium diaphragm compression driver. The system's plywood enclosure features a 15° down angle baffle and Array Optimized Tuning (AOT) for optimum frequency response. The 200 watt continuous power rating and sophisticated crossover provides absolute reliability.

The compact black enclosure with black grille blends into any theatre decor. A new QuickMount bracket design allows for fast, easy and secure installation. The loudspeaker half of the bracket comes pre-installed on each SR-110B. The QuickMount wall bracket is purchased separately to allow shipment to the job site ahead of the loudspeakers. A traditional U-bracket is also available in lieu of the QuickMount bracket system.

Specifications

Frequency Range ¹	
-6 dB half space	50 Hz – 20 kHz
-10 dB half space	42 Hz – 20 kHz
Nominal Coverage	90° horizontal x 85° vertical (averaged from 1 kHz to 10 kHz, -6 dB)
Directivity Index	7.5 dB
Q	5.6
Maximum Output ²	
Calculated Peak at Rated Power	123 dB
Calculated Continuous	117 dB
Impedance	8Ω nominal
Maximum Input Power ³	
100 hours of 6 db crest factor IEC 268 noise spectrum	150 W RMS
2 hours of 6 db crest factor pink noise, 50 Hz – 20 kHz, AES method	200 W RMS
Recommended Amplifier Power	400 W RMS maximum into 8Ω
Sensitivity 1 watt/1 meter, half space	94 dB
Crossover Frequency	2.6 kHz
Recommended Processing	Subsonic filter at 50 Hz as provided by QSC DCA amplifiers
Connectors	Barrier strip screw terminals accept up to #10 AWG stranded wire
Transducers	10" long throw low-frequency transducer 1" titanium diaphragm compression driver on a CD horn
Enclosure	Plywood, baffle angle is 15° downward
Dimensions (HWD)	23" x 12" x 12.25" (584 mm x 304 mm x 311 mm)
Weight – Net	31 lb (14 kg)

1) All frequency ranges specified refer to measured free field response (half space, 2π).

2) Calculated SPL at 1m, (half space, 2π), speaker operating at rated RMS power with pink noise within specified frequency range.

3) Maximum input power tested in accordance with IEC 268-5 recommendations, 50 Hz – 20 kHz band limiting, 6 dB signal crest factor.

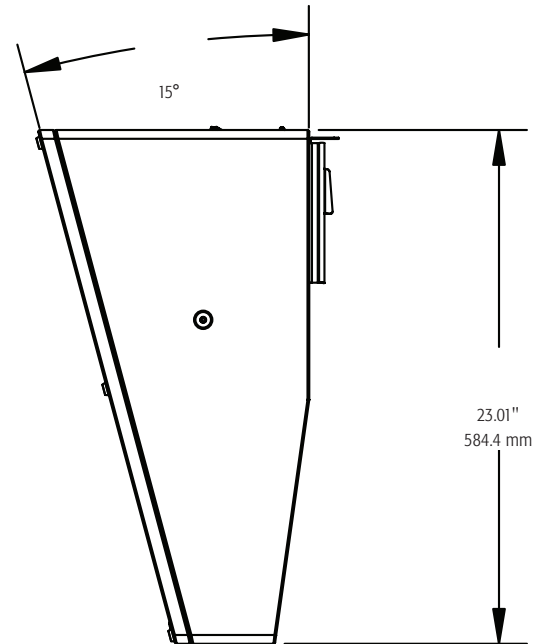
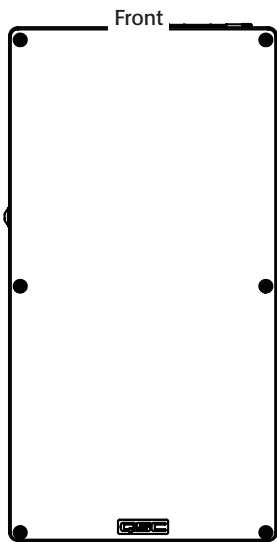
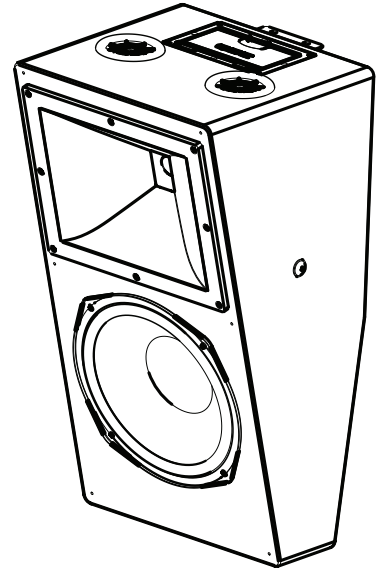
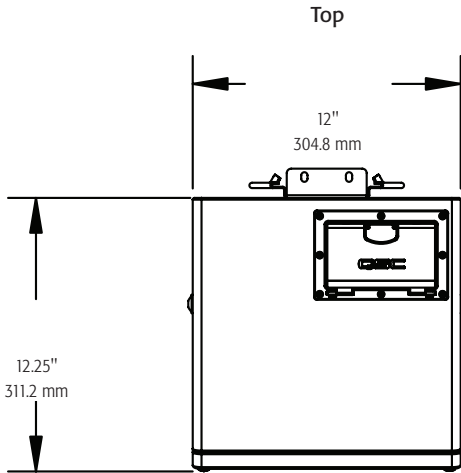

Side

Specifications subject to change without notice.



©2009 QSC Audio Products, LLC. All rights reserved. QSC, and the QSC logo are registered trademarks of QSC Audio Products, LLC in the U.S. Patent and Trademark office and other countries. THX is a trademark of THX Ltd. All other trademarks are the property of their respective owners. Patents may apply or be pending.

1675 MacArthur Boulevard • Costa Mesa, CA 92626 • Ph: 800/854-4079 or 714/957-7100 • Fax: 714/754-6174

SR-110B Spec Sheet - 03/01/10

QSC
qscaudio.com