

Features of the WL2082-i

- Installation-optimized design brings affordable and uncompromised line array performance to a broader range of venues
- True line array performance – individual speaker elements are designed to function in a coherent array
- Compact and attractive appearance, available in black and white, harmonizes with any installation environment
- Wide 140° horizontal coverage
- Economical and easy-to-install suspension system with ample array adjustability

Features of the WL115-sw

- Single 15" subwoofer in a 4th order bandpass enclosure
- 650 watt power capacity
- Frequency range to 35 Hz
- May be suspended at the top of a WL2082-i array or behind the array (requires optional accessory items)
- Available in black or white to harmonize with venue décor



Line array systems have become the primary loudspeaker configuration for tour sound and many large installations. With the advent of the WideLine WL2082-i Installation Line Array (ILA), QSC offers a professional system at breakthrough pricing making line array performance accessible to a far broader range of house of worship and performance venues. Most line array systems currently available are designed for touring applications. As a result, the overall system cost is driven beyond the means of many facilities that could benefit from line array acoustic performance. By focusing on installation applications, using a molded enclosure and simplifying the rigging design, QSC was able to drive cost out of the system while retaining the sound quality, coverage and power of high end touring systems.

Each Installation Line Array element uses a pair of high-power, neodymium magnet, 8" diameter low-frequency drivers in a two-and-a-half way configuration. Both woofers produce low frequencies but only one covers the mid-range resulting in more uniform directivity in the crossover region. For high frequencies, a pair of 1.75" (voice-coil diameter) neodymium compression drivers with titanium domes are

mounted on a multiple aperture diffraction waveguide that provides extremely wide coverage (140°). As a result, a WL2082-i system will rarely require additional side or center fill speakers and solid stereo imaging is preserved across the listening area.

The system may be used in bi-amplified or tri-amplified mode. In general, the tri-amplified mode will produce the best performance and, for arrays larger than four boxes, will not increase the total cost of system amplification.

The low-frequency range of a WL2082-i array will be adequate for speech, voice and many acoustic music uses. For reinforcement of program material with more demanding low frequency content a companion subwoofer, the WL115-sw, is also available. The WL115-sw is a 15" subwoofer using a 4th order, bandpass enclosure. Tooled ports with gently rounded terminations inside and out eliminate port turbulence distortion. Mesh grilles are integrated into the port design to obstruct the entrance of foreign objects into the enclosure.

Many users of line array systems have found that suspending the subwoofers with the array provides audible benefits. In addition, some

venues lack room for floor mounted subs. For these reasons, the WL115-sw includes rigging hardware and, with selection of the appropriate rigging accessories, subwoofers may be flown at the top of an array or behind as pictured.

Rigging for the ILA is simple, flexible and safe providing a 10:1 design factor with twelve WL2082-i systems in the array (see the owner's manual for details before planning any array suspension). The array is assembled with the included bolts and the relative angle between adjacent boxes is adjustable in 1° increments for precise tailoring of vertical coverage. For those who prefer quick release pins to the included bolts, an optional kit of four quick release pins is available.

Available in black or white, the WL2082-i enclosure is made of high impact polystyrene with extensive internal ribs to eliminate acoustic losses due to sidewall flex. The Installation Line Array may be used in outdoor applications where the system is not directly exposed to the elements. The enclosure material is formulated with UV inhibitors, the grille is made of aluminum and the woofer cones are weather resistant.

ILA Series Installation Line Array

	WL2082-i	WL115-sw																									
Configuration	2½-way, bi-amp or tri-amp mode	4th order bandpass subwoofer																									
Transducers																											
High-frequency	Dual 50 W, 8Ω 1" exit, 1.75" titanium diaphragm, neodymium magnet assembly	–																									
Low-frequency	Dual 200 W, 16Ω 8" woofer, 2" voice coil, neodymium magnet assembly, weather resistant cone	650 W, 8Ω 15" woofer with a 4" voice coil, ceramic magnet assembly																									
Frequency Response (±3 dB)	80 Hz – 20 kHz	37 Hz – 107 Hz																									
Frequency Range (-10 dB)	68 Hz – 22 kHz	35 Hz – 112 Hz																									
Nominal Impedance	HF: 16Ω LF bi-amp mode: 8Ω LF tri-amp mode: 16Ω (x 2)	– – LF: 8Ω																									
Continuous Power Capacity ¹ / Recommended Power	HF: 100 W / 200 W LF bi-amp mode: 400 W / 800 W LF tri-amp mode: 200 W / 400 W (x 2)	– – LF: 650 W / 1300 W																									
Sensitivity (1 W at 1 m)	HF: 106 dB LF: 96 dB	– LF: 96 dB																									
Maximum Output Continuous / Peak (SPL at 1 m)	HF: 126 dB / 132 dB LF: 122 dB / 128 dB	LF: 124 dB / 130 dB																									
Nominal Coverage	H: 140° V: dependent on number of elements used	– –																									
Cabinet Type	Ported, elliptical/trapezoidal	4th order bandpass																									
Enclosure Material	HIPS (high impact polystyrene) with UV protectant	18 mm baltic birch plywood																									
Finish	Available in black (WL2082-i BLK) or white (WL2082-i WHT) paintable	Available in black (WL115-sw BLK) or white (WL115-sw WHT) paintable																									
Grille	Perforated, formed aluminum	–																									
Connectors	2 x NL8 in parallel	2 x NL8 in parallel																									
Pin Outs	<table border="1"> <thead> <tr> <th>Pins</th> <th>Bi-Amp</th> <th>Tri-Amp</th> </tr> </thead> <tbody> <tr> <td>1+/1-</td> <td>NC</td> <td>NC</td> </tr> <tr> <td>2+/2-</td> <td>NC</td> <td>LF2</td> </tr> <tr> <td>3+/3-</td> <td>LF</td> <td>LF1</td> </tr> <tr> <td>4+/4-</td> <td>HF</td> <td>HF</td> </tr> </tbody> </table>	Pins	Bi-Amp	Tri-Amp	1+/1-	NC	NC	2+/2-	NC	LF2	3+/3-	LF	LF1	4+/4-	HF	HF	<table border="1"> <thead> <tr> <th>Pins</th> <th>Sub</th> </tr> </thead> <tbody> <tr> <td>1+/1-</td> <td>Sub</td> </tr> <tr> <td>2+/2-</td> <td>NC</td> </tr> <tr> <td>3+/3-</td> <td>NC</td> </tr> <tr> <td>4+/4-</td> <td>NC</td> </tr> </tbody> </table>	Pins	Sub	1+/1-	Sub	2+/2-	NC	3+/3-	NC	4+/4-	NC
Pins	Bi-Amp	Tri-Amp																									
1+/1-	NC	NC																									
2+/2-	NC	LF2																									
3+/3-	LF	LF1																									
4+/4-	HF	HF																									
Pins	Sub																										
1+/1-	Sub																										
2+/2-	NC																										
3+/3-	NC																										
4+/4-	NC																										
Attachment Points	Integral, side plate adjustable rigging system, vertical splay adjustable in 1° increments from 0° – 10°	Integral, non-adjustable (straight array only)																									
Weight (Net / Shipping)	37 lb (16.8 kg) / 45 lb (20.45 kg)	111 lb (50.4 kg) / 121 lb (55 kg)																									
Dimensions (HWD)	11.8" x 27" x 13.4" (300 mm x 686 mm x 340 mm)	22.1" x 27" x 30.25" (561 mm x 686 mm x 768 mm)																									
Accessories Available	FB2082-i: Fly-bar for WL2082-i and WL115-sw. Available in black or white. EB2082-i: Extension bar, allows WL115-sw to be suspended behind WL2082-i. Available in black or white. PB2082-i: Pullback bar for WL2082-i. For use when pulling back the bottom of the array is necessary to achieve the desired angle. Available in black or white. QRP-KIT-1: Kit of four (4) Quick Release Pins for use in lieu of included bolts.																										

1) 2 hours, IEC specified noise

Specifications subject to change without notice.

Array Configurations

The following table provides information regarding the maximum number of WL2082-i line array elements and WL115-sw subwoofers that may be suspended using various configurations of the available suspension accessories. The calculations for this table are based on a 10:1 design factor. See owner's manual for detail before designing or suspending array. While a single WL2082-i may be used for some specialized applications such as stage lip front fill, or under balcony fill three or more ILA elements are required before the system begins to perform as a true line array.

Configuration	Maximum WL2082-i in array	Maximum WL115-sw in array
Single FB2082-i	12	0
	8	2
	5	3
	0	4
Dual FB2082-i with EB2082-i (subwoofers behind line array)	12	3
	10	4



Aiming the ILA

Aiming and array configuration of an ILA system is supported by EASE Focus. Focus is a two-dimensional acoustic simulation application that calculates vertical coverage of a venue by a line array system. This free software may be downloaded from the support section of the QSC website at www.qscaudio.com.

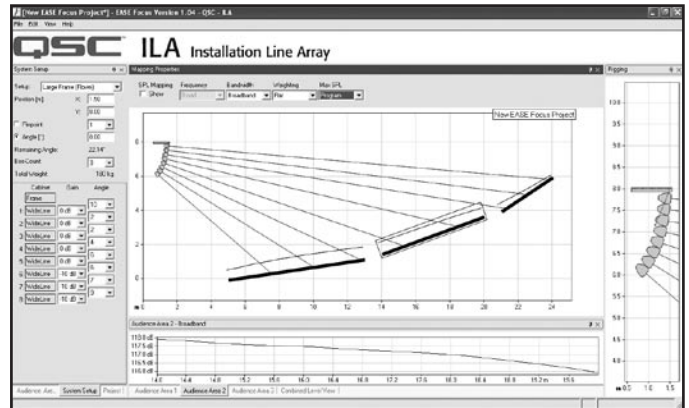

Horizontal Polar Plots (Individual enclosure)

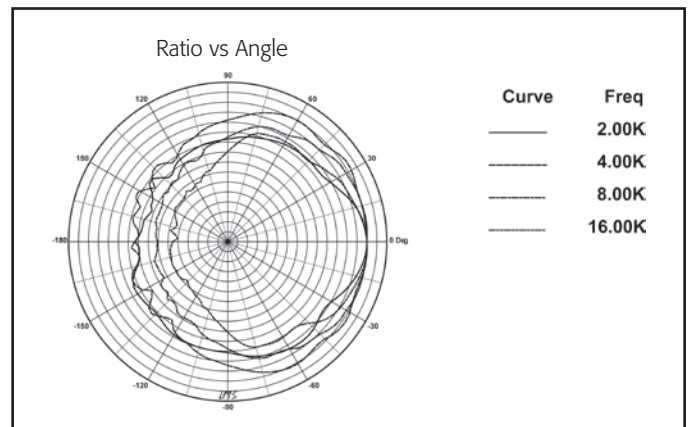
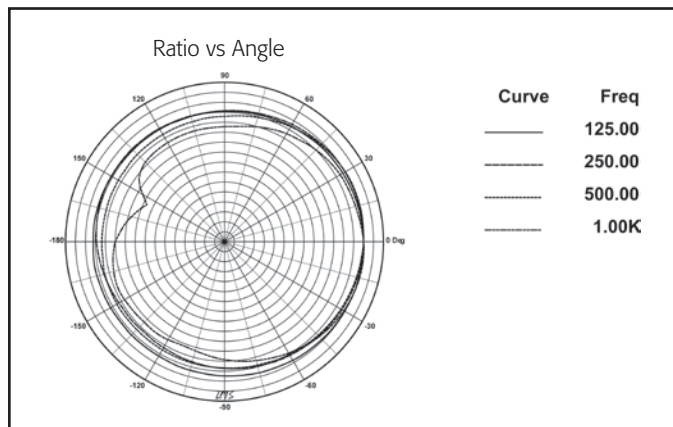

WL2082-i

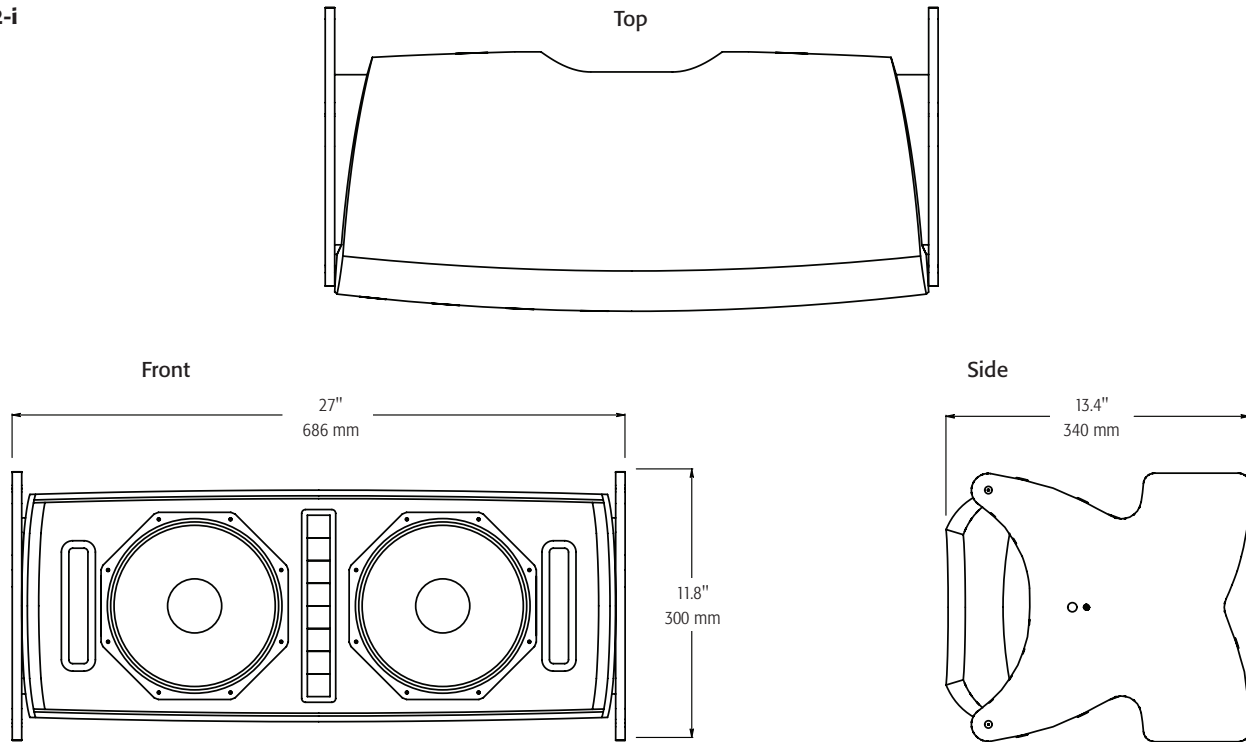

WL115-sw

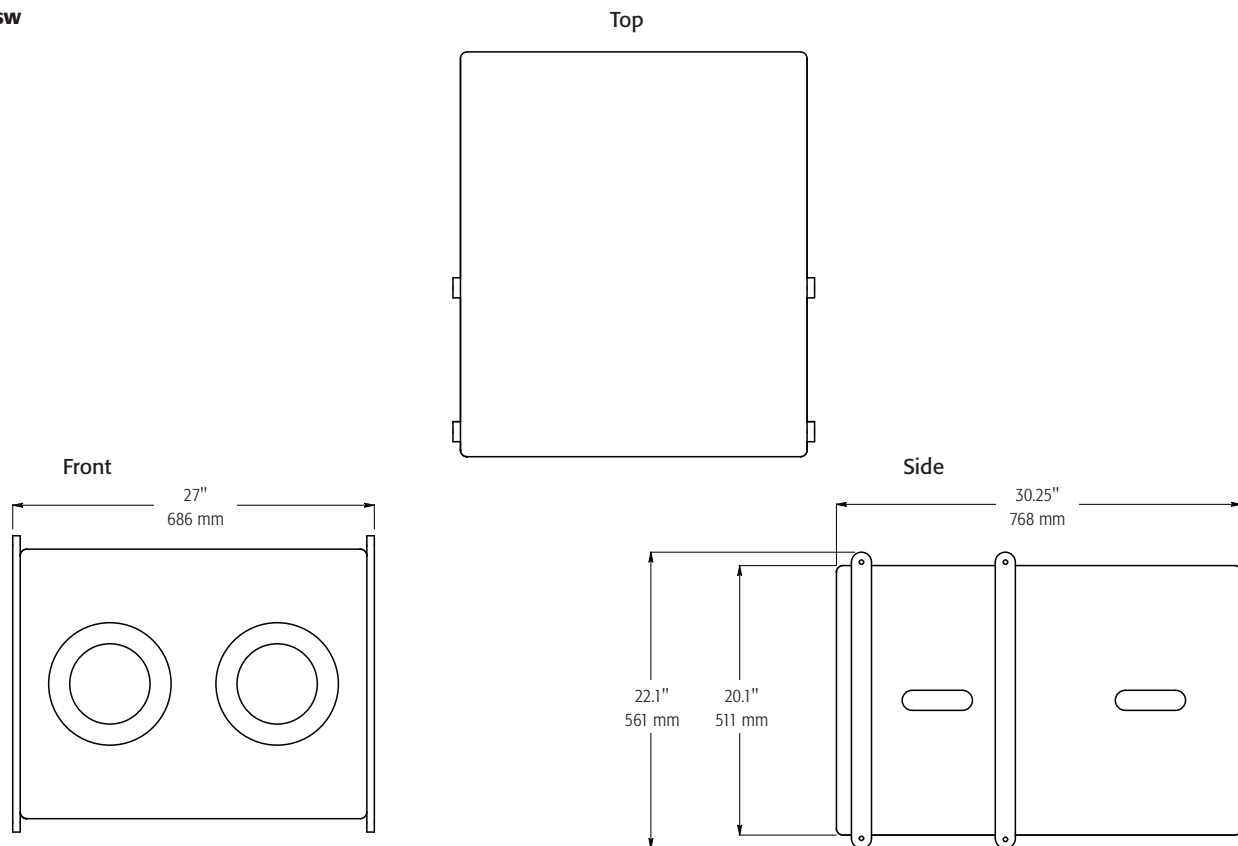

Specifications subject to change without notice.

QSC and the QSC logo are registered trademarks of QSC Audio Products, LLC in the U.S. Patent and Trademark office and other countries. All other trademarks are the property of their respective owners. Patents may apply or be pending.

1675 MacArthur Boulevard • Costa Mesa, CA 92626 • Ph: 800/854-4079 or 714/957-7100 • Fax: 714/754-6174

ILA Spec Sheet 10/14/08